

Slip Op. 25-19

UNITED STATES COURT OF INTERNATIONAL TRADE

- - - - -x Senior Judge Aquilino

NANJING KAYLANG CO., LTD., :

Plaintiff, :

v. : Court No. 24-00045

UNITED STATES, :

Defendant, :

-and- :

AMERICAN KITCHEN CABINET ALLIANCE, :

Intervenor-Defendant. :

- - - - -x

Opinion

[Plaintiff's motion for judgment upon agency record denied; action dismissed.]

Decided: February 21, 2025

David J. Craven, Craven Trade Law LLC, Chicago, IL, for the plaintiff.

Ashley Akers, Trial Attorney, Commercial Litigation Branch, Civil Division, U.S. Department of Justice, Washington, D.C., for the defendant. With her on the brief Brian M. Boynton, Principal Deputy Assistant Attorney General, Civil Division, Patricia M. McCarthy, Director, and Tara K. Hogan, Assistant Director. Of counsel on the brief Heather Holman, Attorney, Office of Chief Counsel for Enforcement and Compliance, U.S. Department of Commerce, Washington, D.C.

Luke A. Meisner and Alessandra A. Palazzolo, Schagrin Associates, Washington, D.C., for the intervenor-defendant.

Court No. 24-00045

Page 2

AQUILINO, Senior Judge: The plaintiff contests the final scope ruling of defendant International Trade Administration ("ITA"), U.S. Department of Commerce, that its products, manufactured in the People's Republic of China ("PRC"), are subject to the 2020 antidumping-duty ("AD") and countervailing-duty ("CVD") orders on Wooden Cabinets and Vanities and Components Thereof therefrom.¹ See Memorandum, "Wooden Cabinets and Vanities and Components Thereof from the People's Republic of China: Kaylang Phragmites Scope" (Dep't Commerce Jan. 12, 2024)², Public Record ("P.R.") 30 ("Scope Ruling").

The American Kitchen Cabinet Alliance ("AKCA"), intervening in support of that ruling alongside the defendant, opposes plaintiff's interposed USCIT Rule 56.2 motion for judgment on the agency record.³

¹ See Wooden Cabinets and Vanities and Components Thereof From the People's Republic of China: Antidumping Duty Order, 85 Fed.Reg. 22126 (Dep't Commerce April 21, 2020) ("AD Order"); Wooden Cabinets and Vanities and Components Thereof From the People's Republic of China: Countervailing Duty Order, 85 Fed.Reg. 22134 (Dep't Commerce April 21, 2020) ("CVD Order") (collectively, "Orders").

² Not published in the Federal Register.

³ See Pl's Mot. J. on Agency Rec. ("Pl's Br."), ECF No. 21; Def's Resp. to Pl's Mot. J. on Agency Rec. ("Def's Resp."), ECF No. 23; Int-Def's Resp. to Pl's Mot. J. on Agency Rec. ("Int-Def's Resp."), ECF No. 22. Plaintiff did not file a reply brief.

I

At issue is ITA's interpretation of the 2020 AD and CVD

Orders that encompass

[w]ooden cabinets and vanities and wooden components . . . made substantially of wood products, including solid wood and engineered wood products (including those made from wood particles, fibers, or other wooden materials such as plywood, strand board, block board, particle board, or fiberboard), or bamboo.

AD Order, 85 Fed.Reg. at 22132; CVD Order, 85 Fed.Reg. at 22135.

Based on Nanjing Kaylang's Scope Ruling Application, P.R.

1, ITA's Scope Ruling describes its products as

cabinets and vanities made from phragmites, a common reed with various scientific names starting with "Phragmites." This plant is a perennial wetland grass that can grow up to 15 feet high.

Phragmites are cut into specific lengths, dried, ground into particles, mixed with glue, flattened into a sheet and spread to form a surface layer over a core layer. The layers are cold pressed, then hot pressed, sanded, and finished, where melamine paper^[4] is applied to the surface using high temperature and high pressure, thus completing the process for phragmite composite board. After the composite board is produced, the cabinet or vanity is produced using traditional furniture production processes.

Scope Ruling at 5 (footnotes omitted).

Nanjing Kaylang argued that its cabinets and vanities produced from phragmites should be classified under HTSUS

⁴ Melamine is a plastic. See P.R. 1 at 3.

Court No. 24-00045

Page 4

subheading 1404.90.9090, Vegetable Products, not elsewhere specified or included; other; other. See id. at 7. ITA ultimately determined that the cabinets manufactured in the PRC from phragmite composite boards are covered by the scope of the Orders. Id. at 10.

Explaining its rationale, ITA acknowledged that the scope's language includes cabinets and vanities produced from "engineered wood products (including those made from wood particles, fibers, or other wooden materials such as plywood, strand board, block board, particle board, or fiberboard), or bamboo", id. at 2, but reasoned that the language does not clearly state "whether engineered wood products would include cabinets and vanities made from fibers and particles other than wood". To ITA's thinking, "engineered wood" is ambiguous, thus necessitating resort to considering secondary sources pursuant to 19 C.F.R. 351.225(k)(1)(ii). Id. at 9. The secondary interpretative sources ITA then considered, such as Customs and Border Protection ("CBP") rulings and explanatory notes on classifications from the World Customs Organization ("WCO") and the International Trade Commission ("ITC"), persuaded it that plaintiff's "phragmite composite" boards are a type of "engineered wood." See id.

Court No. 24-00045

Page 5

ITA also examined plaintiff's manufacturing process for phragmite composite board and found that it "is very similar to the production process for manufacturing particle board." Id. at 9.

This appeal ensued.

II

Jurisdiction herein is pursuant to 28 U.S.C. §1581(c). This action concerns "[a] determination by [ITA] as to whether a particular type of merchandise is within the class or kind of merchandise described in an . . . antidumping or countervailing duty order." 19 U.S.C. §1516a(a)(2)(B)(vi). In such a matter, the standard of judicial review is whether the final determination is "unsupported by substantial evidence on the record, or otherwise not in accordance with law." Id. §1516a(b)(1)(B)(i). And in that review, ITA's Scope Ruling is presumed to be correct, with the burden on the plaintiff to prove otherwise. 28 U.S.C. §2639(a)(1).

III

To clarify whether a particular product is within the scope of an unfair trade order, ITA will issue a scope ruling. See 19 C.F.R. §351.225(a). Its inquiry begins with the relevant scope language to determine whether it is plain or ambiguous. See OMG, Inc. v. United States, 972 F.3d 1358, 1363 (Fed.Cir. 2020). If it

Court No. 24-00045

Page 6

is unambiguous, the plain meaning obviously controls the outcome. Id. When it is ambiguous, since no specific statute addresses the interpretation of an order's scope, ITA is guided by case law and agency regulations. See Meridian Prods., LLC v. United States, 851 F.3d 1375, 1382 (Fed.Cir. 2017); 19 C.F.R. §351.225. These sources aid ITA's inquiry:

(A) The descriptions of the merchandise contained in the petition pertaining to the order at issue;

(B) The descriptions of the merchandise contained in the initial investigation pertaining to the order at issue;

(C) Previous or concurrent determinations of the Secretary, including prior scope rulings, memoranda, or clarifications pertaining to both the order at issue, as well as other orders with same or similar language as that of the order at issue; and

(D) Determinations of the Commission pertaining to the order at issue, including reports issued pursuant to the Commission's initial investigation.

19 C.F.R. § 351.255(k) (1) (i) .

ITA may also consider secondary interpretive sources, including: any other of its determinations or by the ITC; rulings or determinations by CBP; industry usage; dictionaries; and any other relevant record evidence. Id. § 351.255(k) (1) (ii) . If there is a conflict between such secondary interpretive sources and the primary interpretive sources of this section, the primary

interpretive sources will normally govern in determining whether a product is covered by the scope of the order at issue. Id.

Finally, if the (k)(1) sources do not dispositively answer the question, ITA may consider the (k)(2) factors⁵:

- (i) The physical characteristics of the product;
- (ii) The expectations of the ultimate purchasers;
- (iii) The ultimate use of the product;
- (iv) The channels of trade in which the product is sold;
and
- (v) The manner in which the product is advertised and displayed.

19 C.F.R. §351.225(k)(2). Id.

In this process, ITA cannot interpret the scope so as to change its intended meaning, nor can it interpret the language in a manner contrary to the unfair trade order's terms overall. See King Supply Co. LLC v. United States, 674 F.3d 1343, 1348 (Fed.Cir. 2012); Eckstrom Indus., Inc. v. United States, 254 F.3d 1068, 1072 (Fed.Cir. 2001). In other words, when a party challenges a scope determination, in ruling on whether ITA's decision is unsupported by substantial evidence or not in accordance with law, the Court

⁵ See Diversified Products Corp. v. United States, 6 CIT 155, 162, 572 F.Supp. 883, 889 (1983).

must determine whether the scope of the order "contain[s] language that specifically includes the subject merchandise or may be reasonably interpreted to include it." Duferco Steel, Inc. v. United States, 296 F.3d 1087, 1089 (Fed.Cir. 2002).

IV

The scope of the Orders encompasses

wooden cabinets and vanities that are for permanent installation (including floor mounted, wall mounted, ceiling hung or by attachment of plumbing), and wooden components thereof. Wooden cabinets and vanities and wooden components are made substantially of wood products, including solid wood and engineered wood products (including those made from wood particles, fibers, or other wooden materials such as plywood, strand board, block board, particle board, or fiberboard), or bamboo....

Scope Ruling at 2.

Given such language, the plaintiff argues that the scope of the Orders is limited to articles of wood. It submits that the cabinets in question were made out of phragmites, which ITA specifically and clearly found were "not wood". Plaintiff's position, thus, is that

[t]he first sentence of the scope expressly references "wooden" as the characterization of the term cabinet and also the "wooden" components. The second sentence again refers to wooden cabinets made substantially of wood products and engineered wood products including solid wood and engineered wood products. The scope then further characterizes the engineered wood products as

those made from wood particles, fibers, or other wooden materials such as plywood, strand board, block board, particle board, or fiberboard[]. The scope then also names bamboo, and only bamboo[,] as an alternate material[]. In other words, every sentence of the scope expressly references wood or is characterized by the word wood or is another expressed material. There is no rational or reasonable interpretation that the scope includes materials not made of wood.

Pl's 56.2 Br. at 8.

Therefore, according to the plaintiff, the sole question here is whether "non-wood" products are within or without the scope of the Orders. Given ITA's finding that phragmite is not wood, plaintiff especially maintains that ITA improperly expanded the term "composite board" in the scope of the Orders to include composite board not made of "wood". Id. at 2.

The plaintiff is correct as to ITA's observation that phragmite is "not wood" for purposes of the Scope Ruling. However, ITA's focus was not on phragmite, per se, but on what it could be processed into:

As demonstrated above, even though phragmite is not wood, it undergoes a manufacturing process that is very similar to the process used to make particle boards, resulting in the production of phragmite particle board, a ligneous board of a woody nature.

Scope Ruling at 10. Although redundant, "ligneous" succinctly captures ITA's rationale, since it means "[o]f the nature of wood;

Court No. 24-00045

Page 10

woody: said esp. of plants and their texture (opposed to herbaceous).” Ligneous, The Oxford English Dictionary (2d ed. 1989) (“OED”), Vol. VIII at 941. The intervenor-defendant also explains that

the scope not only covers cabinets made of “solid wood” but also cabinets made from “engineered wood.” Kaylang’s cabinets are made substantially of phragmite composite boards that are a type of engineered wood product. Thus, they are covered by the scope of the Orders.

Int-Def’s Resp. at 7.

This court can agree with ITA that “engineered wood products” is ambiguous. See Scope Ruling at 9. A hyphen would have helped clarify whether the scope encompasses “engineered-wood products” or “engineered wood-products”. To the extent that the concept of engineering encompasses not only invention or problem-solving but practical application in creation or refinement,⁶ for the purpose of the Orders’ scope, “engineered wood products” must

⁶ “Engineering”, of course, is “the science by which the properties of matter and the sources of energy in nature are made useful to man”, Webster’s Third New International Dictionary Unabridged 752 (1981) (“Webster’s”), and so to “engineer” in the transitive sense means “to use specialized knowledge or skills to develop (a complicated system or process) so as to fulfil specified criteria or perform particular functions; esp. to design and construct (a large-scale machine, structure, etc.), typically for public or industrial use.” Engineer, oed.com, <https://www.oed.com/search/dictionary/?scope=Entries&q=Engineer> (last visited this date); cf. OED, Vol. V at 252.

Court No. 24-00045

Page 11

at least amount to an artfully contrived (i.e., invented) type of "wood", for that is the term employed. In its natural state, technically speaking, "wood" is "[t]he hard compact fibrous substance lying between the bark outside and the pith within" (OED, Vol. XX at 502), or "the hard fibrous substance that makes up the greater part of the stems and branches of trees or shrubs beneath the bark, is found to a limited extent in herbaceous plants, and consists technically of the aggregated xylem elements intersected in many plants with the rays", Webster's at 2630. That hard fibrous substance - cellulose fiber - is the basic building-block shared by all Plantae - one of the "five kingdoms" of living organisms. E.g., Bo Madsen and Kristofer Gamstedt, Wood versus Plant Fibers: Similarities and Differences in Composite Applications, 1 Advances in Materials Science and Engineering (May 14, 2013) at 2, available at <https://onlinelibrary.wiley.com/doi/10.1155/2013/564346> (last visited this date).

There are gradations thereof, as the plaintiff would argue (e.g., the notable distinctions between wood and plant fibers would include higher hemicellulose and lignin content and lower cellulose crystallinity in wood fibers versus plant fibers). See id. That is certainly true of unprocessed fiber in its natural state. However, the focus of this action is processed fiber and

Court No. 24-00045

Page 12

the scope language of "engineered wood products". And the subject merchandise includes cabinets and vanities made from "engineered wood products," including those made from "particles" and "fibers," including specifically "particleboard" and "fiberboard." See, e.g., AD Order, 85 Fed.Reg. at 22132. If ejusdem generis were appropriate at this point, that doctrine would limit such "fibers" only to wood fibers. But, the term employed in the scope language is just that: "fibers" -- set apart from the other terms by commas as part of a series. The term appears unmodified and unqualified, and this court will not read into it any further qualification, when it would have been a simple matter for the domestic industry to clearly state "wood fibers" if such fibers had been their scope intent. Cf. Douglas D. Stokke, Qinglin Wu, and Guangping Han, Introduction to Wood and Natural Fiber Composites (Christian V. Stevens ed., John D. Wiley & Sons, Ltd. 2014) at 2 ("[w]hile it may in some respects resemble the wood of trees, it is generally agreed that monocots such as coconut palm stems do not contain wood per se, but are said to be composed of 'woody material'").

"Engineered wood products", incorporating wood particles, fibers, or other wooden materials, as well as particle board and fiberboard products, are accurately described in the Scope Ruling

Court No. 24-00045

Page 13

by its referential use of "ligneous," which in turn illuminates a broader intended meaning of "wood" as employed in the scope of the Orders: the Scope Ruling describes phragmite particle board as "a ligneous board of a woody nature" (highlighting added). Further, the scope of the Orders broadly covers "[w]ooden cabinets and vanities and wooden components" (highlighting added). In addition to the obvious sense of "wooden," that word also means "resembling wood in stiffness and lack of resilience". Wooden, Webster's at 2631 (highlighting added). ITA's Scope Ruling appears to have interpreted the Orders as conveying both meanings, which is not an unreasonable interpretation.

Furthermore, as AKCA points out, the type of "particle board" that the plaintiff contends is outside the scope of the Orders was not unknown in the industry at the time the scope language was drafted. See Int-Def's Resp. at 3. Describing particle board to ITA as manufactured by pressing and extruding materials, such as wood chips, sawmill shavings or sawdust, straw particles, or reed shavings, combined with a synthetic resin or other suitable binder, AKCA explained that

particle board . . . may be made with reed fibers and shavings. One patent for "reed particle board" describes the manufacturing process as: (1) cutting the reed to a certain size; (2) cutting the resulting material using a

reed cutting machine, where one part of the cut material is cooked and softened to obtain the reed fibers, and the other part of the material is crushed again to obtain fine reed shavings; (3) combining resin with the reed fibers and the shavings to form three-layer or multilayer structural boards; and (4) pre-pressing the boards in a continuous flat-pressing hot press to produce the reed fiber particle board. Id. at Exhibit 3. Similarly, medium-density fiberboard ("MDF") is another type of engineered wood that is manufactured by breaking down plant materials into fibers, often in a defibrator, combining the fibers with wax and a resin binder, and forming panels by applying high temperature and pressure. Id. at Exhibit 4. Like particle board, MDF can be produced from plants in the Poaceae family of grasses, including bamboo, bagasse, and phragmite reeds. Id. at 7-8, Exhibits 5-9. In one study published in 2004, "MDF was produced from Reed (Phragmites australis)" and the resulting physical and mechanical properties of the MDF were determined according to the relevant industry standards. Id. at Exhibit 8. In a later study published in 2010, the detailed characteristics of reed were analyzed, and the effects of density and adhesive content on the physical and mechanical properties of reed-based MDF were investigated. Id. at Exhibit 9.

AKCA Response to Scope Request (April 27, 2023), P.R. 7, at 6-7 (summarizing Patent CN104227819A (China): Preparation method for reed fiber particle board (2014), attached to AKCA Response to Scope Request as Exhibit 3). Presented with such information, in ruling on Kaylang's scope application ITA further observed that phragmites are indeed a member of a family of grasses consistently found to be "wood articles" and "of a woody nature", and that

Court No. 24-00045

Page 15

multiple agencies including the ITC and CBP "have classified articles made of ligneous materials as wood articles, and furniture made of bamboo, which is classified as belonging to the same family of grasses as phragmites, classified as wood." Scope Ruling at 9-10. ITA's conclusion therefrom that the scope language covered plaintiff's processed phragmite products was and is not unreasonable.

It is, furthermore, not coincidence that "board" naturally or typically connotes to the mind the association of a product that is of wood or wooden, see, e.g., board, Webster's at 243 ("piece of sawed lumber . . . 5 a : a flat usu. rectangular piece of material (as wood) . . . 6 a : any of various wood pulps or composite materials formed or pressed into somewhat stiff or rigid flat usu. rectangular sheets; specif : material of the same general composition as paper but stiffer and usu. thicker, being in one classification 12/1000 inch thick . . ."), and plaintiff's natural references to its product among its papers consider it a type of board. See, e.g., Pl's 56.2 Br. at 2 ("[t]he cabinets in question were made of composite board made out of Phragmites"; "cabinets made from fiber board made from Phragmites").

Court No. 24-00045

Page 16

V

In the light of the foregoing, this court cannot conclude ITA's Scope Ruling unsupported by substantial evidence on the record or otherwise not in accordance with law. Ergo, plaintiff's motion for judgment on the agency record must be denied, with judgment entered accordingly.

Decided: New York, New York
February 21, 2025

/s Thomas J. Aquilino, Jr.
Senior Judge

Engineer - Quick search results

 [oed.com/search/dictionary](https://www.oed.com/search/dictionary)

engineer, n.

Originally: a person who designs or builds engines or other machinery. Subsequently more generally: a person who uses specialized knowledge or skills...

[View entry](#)

engineer, v.

transitive. To use specialized knowledge or skills to develop (a complicated system or process) so as to fulfil specified criteria or perform...

[View entry](#)

Review Article

Wood versus Plant Fibers: Similarities and Differences in Composite Applications

Bo Madsen¹ and E. Kristofer Gamstedt²

¹ *Department of Wind Energy, Section of Composites and Materials Mechanics, Risø Campus, Technical University of Denmark, 4000 Roskilde, Denmark*

² *Department of Engineering Sciences, Ångström Laboratory, Uppsala University, 75121 Uppsala, Sweden*

Correspondence should be addressed to Bo Madsen; boma@dtu.dk

Received 10 January 2013; Accepted 31 March 2013

Academic Editor: Dachamir Hotza

Copyright © 2013 B. Madsen and E. K. Gamstedt. This is an open access article distributed under the Creative Commons Attribution License, which permits unrestricted use, distribution, and reproduction in any medium, provided the original work is properly cited.

The work on cellulose fiber composites is typically strictly divided into two separated research fields depending on the fiber origin, that is, from wood and from annual plants, representing the two different industries of forest and agriculture, respectively. The present paper evaluates in parallel wood fibers and plant fibers to highlight their similarities and differences regarding their use as reinforcement in composites and to enable mutual transfer of knowledge and technology between the two research fields. The paper gives an introduction to the morphology, chemistry, and ultrastructure of the fibers, the modeling of the mechanical properties of the fibers, the fiber preforms available for manufacturing of composites, the typical mechanical properties of the composites, the modeling of the mechanical properties with focus on composites having a random fiber orientation and a non-negligible porosity content, and finally, the moisture sensitivity of the composites. The performance of wood and plant fiber composites is compared to the synthetic glass and carbon fibers conventionally used for composites, and advantages and disadvantages of the different fibers are discussed.

1. Introduction

Composites based on cellulose fibers from wood and plants constitute a relatively new and promising class of composite materials [1–4]. They are environmentally friendly, and they offer good technical performance. For several load-carrying applications, where glass or carbon fiber composites are conventionally used, cellulose fiber composites can be a worthwhile alternative. This is particularly the case for applications where the green advantages (renewability, biodegradability) play an important role, and top-end mechanical properties are not the primary motivation. A vast amount of scientific literature on cellulose fibers for composite applications has been compiled during the last decade (e.g., see recent reviews [5–8]), although the publications tend to be divided into two separate fields depending on the origin of the fibers, that is, from wood or annual plants. The reason for this division is perhaps that the raw materials producers are looking for

new markets for their fibers (technology pull), and that the end-users (market pull) have yet to exploit the potential of cellulose fibers, independent of the origin of the fibers. The raw materials producers in this case, that is, forestry for wood fibers and agriculture for plant fibers, have developed their specific technologies along the value chain to produce fibers depending on the traditional usage of the fibers. For wood fibers, pulp mills have been built to produce raw materials for making paper and board. For plant fibers, textile technologies are refined to produce yarns and fabrics. In view of the maturing research field of cellulose fibers shifting towards achieving the technical performance demands of the end-users, and the rather independent existence of research communities of wood and plant fibers, respectively, this paper has been written to shed some further light on the similarities and differences of these two types of cellulose fibers (wood and plant origin), with regard to industrial usage to produce cellulose fiber composites for structural applications. The

performance of the fibers will also be compared to the main current competitors, that is, composites made from synthetic fibers, such as glass and carbon fibers. Similarities and differences of the different fibers for composites will be discussed, in light of future potentials in engineering applications. By bringing the disciplines of wood and plant fiber science closer together, one could hope for a mutual transfer of knowledge, as the two research fields have evolved rather independently and have thus reached different levels of understanding with regard to various aspects, such as characterization methods, fiber treatment, fiber preform processing, and composite manufacturing.

The paper presents an introduction to (i) the morphology, chemistry and ultrastructure of the fibers, (ii) the modeling of the mechanical properties of the fibers, (iii) the fiber preforms available for manufacturing of composites, (iv) the typical mechanical properties of the composites, (v) the modeling of the mechanical properties of the composites with special focus on composites having a random fiber orientation and a non-negligible porosity content, and (vi) the moisture sensitivity of the composites. Furthermore, examples of new composite applications are given, followed by considerations of the future perspective of using wood and plant fibers to produce cellulose nanofiber composites. Finally, an outline of the differences and resulting advantages of the two types of cellulose fibers, namely, wood and plant fibers, is given, as well as the differences and resulting advantages of cellulose fibers versus synthetic fibers.

2. Morphology, Chemistry, and Ultrastructure of Fibers

Plantae is the one of the five kingdoms of living organisms that includes green plants, that is, mosses, ferns, gymnosperms (e.g., softwood), and angiosperms (e.g., hardwood and annual plants). The cells of green plants are surrounded by a rigid *cell wall*, and this is the main characteristic distinguishing them from cells in animals. In some types of cells, the cell walls are enlarged to have superior mechanical properties, which provide the required structural performance of the plants. The dimensions of these so-called fibers vary between different plants but their overall shape is most often elongated with lengths in the range 1–50 mm, and diameters in the range 15–30 μm . In the perspective of composite reinforcement, it is convenient to group the fibers by their lengths.

- (i) Short fibers (1–5 mm), originating typically from wood species (e.g., spruce, pine, birch, eucalyptus), and typically used for making composites with in-plane isotropic properties, that is, composites with a non-specific (random) fiber orientation.
- (ii) Long fibers (5–50 mm), originating typically from annual plant species (e.g., flax, hemp, jute), and typically used for making composites with anisotropic properties, that is, composites with a specific fiber orientation.

In the living green plants, when the fibers are fully developed, their intracellular organelles start to degenerate resulting in fibers having an empty central cavity, the so-called lumen. In wood fibers, the luminal area is in the range 20–70% of the fiber cross-sectional area [9]. In contrast, annual plant fibers, such as hemp and flax, have a relatively smaller luminal area in the range 0–5% [3, 10].

The main chemical constituent of the cell wall is cellulose, which is a non-branched polysaccharide polymer made up of glucose units. For wood fibers, the cellulose chain is having an average length of 5 μm corresponding to a degree of polymerization (i.e., glucose units) of 10,000 [9]. This molecular linearity makes cellulose highly anisotropic with a theoretical stiffness and strength of about 130 and 15 GPa, respectively, in the chain direction [11]. The cellulose chains are arranged in parallel to form bundles, which are denoted *microfibrils*. In some regions of the microfibrils, the glucose molecules of the cellulose chains are arranged in a highly ordered crystalline structure. The two other principal chemical constituents of the cell wall are hemicellulose and lignin. Hemicellulose is a heterogeneous group of polysaccharides characterized by being short and branched. Lignin is a highly branched polymer composed of phenylpropane units organized in a complex three-dimensional structure. In addition to the organization of the three chemical constituents, the structural complexity of the cell wall is increased by being organized into a number of layers differing by the angle of the cellulose microfibrils to the longitudinal fiber axis. The angle of the cellulose microfibrils in the various layers, in addition to the relative layer thicknesses, dictates the overall mechanical performance of the fibers. Thus, altogether, the cell wall of wood and plant fibers is essentially organized like a composite laminate with a number of laminae with differently oriented, stiff and strong semicrystalline cellulose microfibrils embedded in a matrix of hemicellulose and lignin.

In contrast to cellulose fibers, the synthetic fibers that traditionally are used for reinforcement in composites, such as glass and carbon fibers, are monolithic and with a much more simple ultrastructure. Glass fibers are primarily composed of silicon oxide molecules organized in an amorphous configuration. Carbon fibers are composed of carbon atoms in graphite layers that are organized in a stackwise turbostratic configuration.

Table 1 shows key numbers of chemical composition and ultrastructure of cellulose fibers. The cellulose content of *unprocessed* fibers is in the range of 40–50% w/w for wood fibers, and in the range of 60–70% w/w for plant fibers. Accordingly, the content of hemicellulose and lignin is higher in wood fibers, and this is particularly true for lignin which shows a content of about 30% w/w in wood fibers, in comparison to only about 5% w/w in plant fibers. The chemical composition of wood and plant fibers is clearly different from each other. In addition, wood fibers show lower cellulose crystallinity than plant fibers, with typical values in the ranges of 55–70 and 90–95% w/w, respectively. The microfibril angle in wood fibers vary in the range 3–50° depending on the type and location of the fibers in the wood (e.g., late and early wood) [12], whereas the microfibril angle in plant fibers is more constant in the range 6–10° [13].

TABLE 1: Chemical composition and ultrastructure of wood and plant fibers.

	Chemical composition			Ultrastructure		Reference
	Cellulose (% w/w)	Hemicellulose (% w/w)	Lignin (% w/w)	Microfibril angle (degrees)	Cellulose crystallinity (% w/w)	
Wood fibers						
Spruce	49	20	29		67	[25]
Pine	42	29	28		57	[26]
Pine (kraft pulp)	76				68	[27]
Cedar	44	21	30		57	[28]
Balsa	48	28	22		56	[26]
Birch	41	32	22		54	[26]
Poplar	39	28	30		54	[28]
Soft wood				3–50		[12]
Plant fibers						
Hemp	63	10	6		96	[25]
Hemp	64	14	3		94	[29]
Hemp (retted)	74	12	5		92	[20]
Hemp (scutched)	66	15	5		98	[29]
Flax (cottonized)	76	14	2		88	[29]
Hemp (textile)	91	7	2			[14]
Hemp and flax				6–10		[13]

The effect of processing treatments on the chemical composition of the fibers is shown in Table 1. In general, for both wood and plant fibers, the cellulose content is increased after processing treatments, due to removal of non-cellulose residues of the fibers (e.g., pectins and waxes). The effect of processing treatment is most clearly seen for the highly processed textile hemp fibers in the study by Madsen et al. [14] where the cellulose content was measured to be as high as 91% w/w.

The influence of growth conditions and processing treatments on the chemistry and ultrastructure of cellulose fibers lead typically to fibers with more variable properties than seen for synthetic fibers. This is frequently considered to be one of the major disadvantages of using cellulose fibers for reinforcement in composites. It is however believed that this concern is caused by a general uncertainty about the cause for the variability in properties, and the lack of a system for classification of the quality of cellulose fibers, for example, similar to the system that exist for classification of solid wood. It should also be mentioned that variability in mechanical properties of fibers can have a positive effect on the notch sensitivity and the fracture toughness of composites [15, 16].

3. Modeling of Mechanical Properties of Fibers

Micromechanical models can be useful in understanding how the chemical composition and ultrastructure of cellulose fibers affect their mechanical properties. From a geometrical point of view, the cell wall in cellulose fibers can be approximated by layers of concentric cylindrical shells.

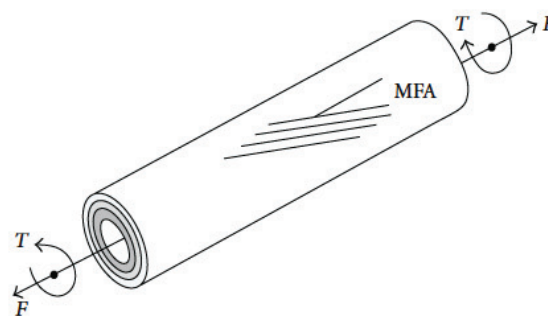

FIGURE 1: Idealized fiber geometry used in micromechanical modeling. MFA is the microfibril angle.

Figure 1 shows such an idealized fiber geometry. Summaries of how the ultrastructural features of the cell wall affect the mechanical properties of the fibers have been compiled by Neagu et al. [17], Salmén and Burgert [18], and Salmén [19].

In principle, the most important mechanical properties of fibers when used in composites are the stiffness and strength in the axial direction, that is, in the fiber length direction. It is in this direction that the fibers are supposed to carry load when used in composites. In the case of cellulose fibers, the key ultrastructural features that affect the axial mechanical properties of the fibers are as follows.

- (i) *Lumen Size*. Only the cell wall carries load, that is, the fiber mechanical properties are proportional to the cell wall cross-sectional area. The larger the relative

lumen size, the lower the stiffness and strength of the fibers.

- (ii) *Cellulose Content*. In a study by Thygesen et al. [20], an increase in the cellulose content of the fibers was found to be well correlated with an increase of their stiffness and strength. In addition, the cellulose crystallinity and the crystallite aspect ratio are known to affect the stiffness of the cell wall in the microfibril direction (e.g., [21]).
- (iii) *Microfibril Angle*. It can be demonstrated with classic laminate theory (in-plane rotation of an orthotropic plate) that the effective elastic properties of the fibers in the axial direction scales with the local stiffness in the microfibril direction multiplied with $\cos^4 \theta$, where θ is the microfibril angle. The fiber stiffness (and strength) is thus very sensitive to the microfibril angle, even if the mechanical properties in the microfibril direction are constant. This trend is also captured by more accurate and detailed micromechanical models (e.g., in the study by Hofstetter et al. [22]). The low microfibril angle of plant fibers makes them highly anisotropic (which also is the case for the synthetic carbon fibers, but not for glass fibers), and this leads to relatively low transverse mechanical properties.

Of the three above-mentioned ultrastructural features, the most important factor to be addressed by the modeling of the mechanical properties of the fibers is probably the microfibril angle, since fiber lumens can either be collapsed (as for earlywood in chemically pulped fibers), or filled with low-viscosity resin during manufacturing of composites, and the cellulose content is an intrinsic property, which is roughly constant for plant fibers and constant, albeit lower, for wood fibers (cf. Table 1). The dependence of the fiber stiffness on the microfibril angle is a well-known effect (e.g., [23]), and can be described by classic laminate theory [24].

4. Preforms of Fibers

The types of preforms of cellulose fibers, to be used for manufacturing of composites, are in principle identical to the ones for synthetic fibers, although concerns must be addressed to some particular characteristics. Here follows details of the preforms of wood and plant fibers.

4.1. Wood Fiber Preforms. Wood fibers are available at a low cost as pulp fibers (Figure 2(a)). These are used to make paper sheets or board materials for packaging. One way to make composites based on wood fibers is to use such fiber mats (Figure 2(b)), which can be impregnated by using for example, a resin transfer molding technique (e.g., [46]). A viscous thermoset resin is impregnating the enclosed wood fiber mat by the aid of a pressure vessel attached to the mold inlet and sometimes also assisted by vacuum suction at the outlet. This manufacturing technique is only adequate for low-viscosity resins, typically thermosets. Thermoplastics usually have a high viscosity in the molten state, and resin transfer molding is not suitable since the



(a)

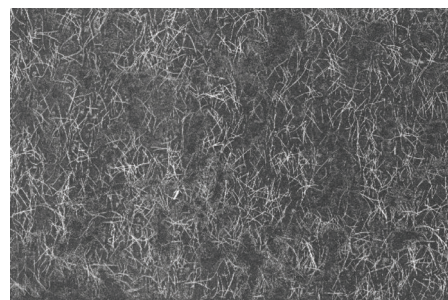

(b)

FIGURE 2: Wood fiber preforms: (a) pulp made from bleached softwood fibers (courtesy of Innventia, Sweden), and (b) wood fiber mat showing fiber distribution (image height ~ 10 mm).

impregnation times would be too high, or the required high pressure would induce severe deformation of the fiber mat. Instead, a commingling technology can be advocated. By using papermaking machines, for example, so-called French or Finnish sheet formers in the laboratory scale, one can produce mats composed of commingled wood pulp fibers and thermoplastic fibers (e.g., [46]). The thermoplastic fibers should preferably have similar dimensions as the pulp fibers, in order to have approximately the same hydrodynamic properties during the formation process, which facilitates efficient mixing. Thermoplastic fibers can be spun to have diameters around $30 \mu\text{m}$ and be chopped to roughly 3 mm lengths (similar to the dimensions of the pulp fibers). When the commingled fiber mat has been dried, it can be placed in a hot press and composite components can be molded. This method is not only limited to flat plates for materials testing, but complex parts with double curvatures can also be made [47].

The papermaking industry encompasses a huge infrastructure to produce wood fiber mats. Anticipated volumes of such fiber preforms for composite applications are extremely small compared with produced volumes of conventional paper and board. Nevertheless, there is an opportunity to build upon the experiences and use small-scale paper mills to produce composite preforms. In the laboratory scale, two main techniques are used to mimic the paper manufacturing process. The most common are sheets produced by dynamic sheet forming and regular handsheets. In dynamic sheet forming, a fiber suspension jet is directed towards a rotating wire drum [48]. The fibers will deposit onto the wire whereas

the water goes through the wire. Depending on the jet to wire speed difference, the fibers will orient along the machine direction (circumferential direction of the rotating drum). An anisotropic sheet can then be obtained, with similar features as those manufactured in paper mills, where the fibers are preferably oriented in the machine direction compared with the cross direction. In the handsheets, the fibers are mixed with water in a large container. The water is abruptly let out at the bottom of the container, and the fibers are deposited on a flat wire at the bottom. The fibers are then predominantly randomly oriented in the plane. Thus, the main difference between sheets that are formed using a dynamic sheet former and handsheets is that the former are generally in-plane anisotropic, whereas the latter are in-plane isotropic.

4.2. Plant Fiber Preforms. The types of plant fiber preforms available for composites are shown in Figure 3. Here follows descriptions of their processing and characteristics.

After the fibers have been extracted from the plants by a retting process, followed by a series of mechanical processes, the fibers can be converted into *non-woven mats* by air-laid and needle-punching techniques [49]. The fiber orientation in non-woven mats is nominally in-plane random, but they can show a preferred fiber orientation in the machine direction [50]. Alternatively, the fibers can be converted into a continuous *yarn* by using various spinning techniques, such as ring spinning, rotor spinning, wrap spinning, and air-jet spinning [51]. Ring spinning is the most widely used method. During spinning, the continuous bundle of almost parallelized fibers (a so-called sliver) is twisted so that the fibers take up a helical configuration. The effect of the fiber twisting angle on the mechanical properties of composites has been addressed in a few studies [52–54]. Furthermore, the cross-sectional area of the yarn (which is specified indirectly by its linear density given in units of g/1000 m), and the degree of yarn compaction are other important yarn characteristics, which however have received limited attention in the perspective of composite reinforcement [14]. It can be speculated that the degree of yarn compaction is correlated with the permeability of the yarn for matrix impregnation during manufacturing of composites. More studies are needed to improve the understanding of the correlation between the various structural characteristics of plant fiber yarns, and the mechanical performance of the yarns in composites.

Plant fiber yarn preforms can be used directly to produce composites by commingled filament-winding together with a thermoplastic filament yarn, followed by compression molding [41], or the yarn can be used to make preforms of woven fabrics and non-crimp fabrics. *Woven fabrics* are fabricated with a range of weaving patterns, such as plain, twill and satin weave, in which the yarns are differently interlaced in the two main, orthogonal, planar directions. The yarns in the two directions can have different linear densities, and they can be placed with different distances to each other. The woven fabrics offer the possibility of having a planar yarn configuration in two dimensions designed to meet the loading profile of a given composite application. Woven

fabrics of flax, jute and cotton fibers are widely available, but they are most often tailored for textile applications, and not for composite applications. *Non-crimp fabrics* consist of yarns that are not held together by being woven into each other, but instead they are stitched together by thin and flexible threads (typically thermoplastic polyester). This means that the yarns are fully stretched; that is, they have no crimp, since they do not have to go over and under each other. Single layers of parallel yarns held together by transversely directed stitching threads are denoted uniaxial non-crimp fabrics. Such uniaxial layers are stacked and stitched together to form biaxial or multiaxial non-crimp fabrics with specific planar yarn orientations, for example, $\pm 45^\circ$, $0^\circ/90^\circ$, and $0^\circ/+45^\circ/-45^\circ/90^\circ$. Recently, a number of European companies have started production of non-crimp fabrics of flax fibers. Thus, for the first time, fabrics of plant fibers that are specifically tailored for composites are commercially available.

5. Mechanical Properties of Composites

The mechanical properties of wood and plant fiber composites have been extensively characterized and analyzed. However, mostly tensile properties, as well as bending and to some extent also impact properties have been characterized, since they are relatively straightforward to measure, and they are commonly used to benchmark different materials in the process of materials development. Other more complex mechanical properties, such as fatigue [55–58] and creep [59] have been studied to a lesser extent.

Table 2 presents typically reported tensile properties (stiffness and strength) of wood and plant fiber composites, together with values for glass and carbon fiber composites. The remarkably high stiffness and strength on 26 GPa and 247 MPa, respectively, for Kraft paper impregnated phenol formaldehyde composites [34] have hitherto not been reached for wood fiber composites. These materials were developed during World War II for use in skins of aircraft wings. Apart from these extreme results by Cox and Pepper [34], it can be observed that cellulose fiber composites (both wood and plant fibers) with a nominal in-plane random fiber orientation, made by using the preforms of loose fibers, paper, and non-woven mats, possess moderate tensile properties with stiffnesses in the range 4–8 GPa and strengths in the range 30–60 MPa. With respect to glass fiber composites, with a similar in-plane random fiber orientation, showing stiffnesses in the range 5–7 GPa and strengths in the range 80–100 MPa, cellulose fiber composites show in general *comparable stiffnesses, and slightly lower strengths*. It is well known that various chemical approaches can be used to control the interface bonding in order to improve the strength of cellulose fiber composites. Acetylation is one type of surface treatment that can be used to reduce the polarity of the fibers making them more compatible with the (typically) non-polar matrix [60]. Also, coupling agents, such as maleic anhydride, can be used to form covalent bonds between the fibers and the matrix [61]. In the study by Clemons [30] (Table 2),

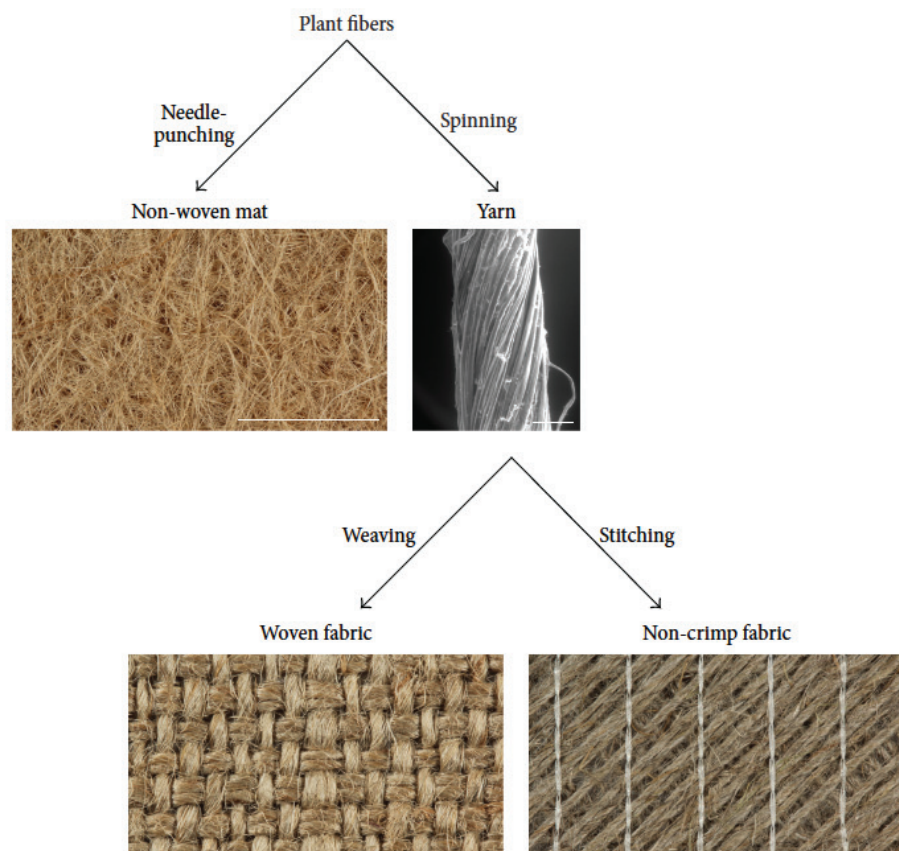

FIGURE 3: Plant fiber preforms. Scale bar is 10 mm for the mat and fabrics, and 0.1 mm for the yarn.

the strength of wood fiber/PP composites were shown to increase from 28 to 52 MPa by using maleic anhydride as a coupling agent, whereas the stiffness did not show any changes. A similar large increase in strength from 40 to 60 MPa has been found in the study of jute fiber/PP composites by Andersen and Plackett [37].

When preforms with nominally unidirectional fibers, such as yarns and non-crimp fabrics are used, the tensile properties of the composites are markedly increased with stiffnesses in the range 20–32 GPa and strengths in the range 130–340 MPa (Table 2). In addition, in comparison to the composites with an in-plane random fiber orientation, the fiber volume content of the unidirectional composites is in general higher (up to 50–55%) [62]. This is related to the better fiber packing ability of aligned fibers as compared to randomly oriented fibers. However, in comparison to synthetic fibers, assemblies of cellulose fibers generally have a lower packing ability [63], which means that the maximum fiber volume content is typically lower in cellulose fiber composites. This is part of the explanation for the lower stiffness of unidirectional cellulose fiber composites, as compared to glass fiber composites, with values of about 30 and 45 GPa, respectively. The contributing stiffness of cellulose fibers in composites has been estimated to be in the range of 20–90 GPa [41], which for the best quality cellulose fibers is comparable to glass fibers with stiffnesses

in the range 70–87 GPa [45]. In terms of strength, unidirectional cellulose fiber composites show radically lower values of about 300 MPa compared to about 1000 MPa for glass fiber composites. The explanation for the low strength of unidirectional cellulose fiber composites is currently not known, however, it is expected that fiber defects, which are introduced to the fibers during their processing, play a large role [64].

The tensile properties in Table 2 well illustrate the current status of cellulose fiber composites where stiffness is acceptable, and comparable to glass fiber composites, but strength needs to be improved. Due to the low density of cellulose fibers, the specific mechanical properties of cellulose fiber composites is particularly competitive compared with glass fiber composites. Furthermore, if these specific properties are normalized with respect to cost, cellulose fiber composites compare well also with carbon fiber composites. In other words, for large volume applications where weight is an issue, for example, in packaging and transport, cellulose fiber composites are likely to be the main contending materials.

6. Modeling of Mechanical Properties of Composites

For composite materials, the quantitative relation between microstructure and mechanical properties is generally

TABLE 2: Tensile properties of wood and plant fiber composites. The type of fiber preforms used for the composites is given, in addition to their nominal fiber orientation; in-plane random (RD) and unidirectional (UD). For means of comparison, tensile properties of glass and carbon fiber composites are shown.

	Fiber content (% v/v)	Tensile properties		Reference
		Stiffness (GPa)	Strength (MPa)	
Wood fiber composites				
Wood pulp/PP ¹ ; RD	27	4.2	28	[30]
Eucalyptus saw dust/UP ¹ ; RD	46	6.2	60	[31]
Kraft + TMP/PP; RD	40	4.5	43	[32]
Sulphite pulp/PP ¹ ; RD	50	3.9	51	[33]
Kraft/PF—paper; RD	72	^a 26.2	247	[34]
Kraft/PF—paper; RD	72	^b 11.7	156	[34]
Plant fiber composites				
Flax/starch—loose fibers ¹ ; RD	37	8.3	51	[35]
Jute/PP—non-woven mat; RD	32	8.4	39	[36]
Jute/PP—non-woven mat; RD	30	5.2	40	[37]
Flax/PLA—non-crimp fabric; UD	39	19.5	150	[38]
Flax/epoxy—non-crimp fabric; UD	35	19.8	234	[39]
Flax/epoxy—yarn ² ; UD	40	28.0	133	[40]
Flax/PET—yarn ² ; UD	48	32.0	344	[41]
Glass fiber composites				
Glass/PP—loose fibers ¹ ; RD	30	7.3	100	[42]
Glass/PP—chopped strand mat; RD	20	5.4	77	[44]
Glass/epoxy—roving; UD	55	39.0	1080	[45]
Glass/PP—roving ² ; UD	60	45.0	1020	[43]
Carbon fiber composites				
Carbon ^c /epoxy—roving; UD	60	313.0	1140	Calculated
Carbon ^d /epoxy—roving; UD	60	142.0	2140	Calculated

¹Injection molding; ²filament-winding.

^aMachine direction; ^bcross direction; ^chigh modulus fibers; ^dhigh strength fibers.

termed micromechanics, and it has been the scope of extensive research for high-performance composites. Micromechanical models developed for these materials are generally applicable also for cellulose fiber composites, with some modifications to account for the specificities of cellulose fibers. By far, the relation between microstructure and elastic properties is the one that has attracted most attention. Stiffness is one of the foremost design parameters, and it is also amenable to modeling efforts since stiffness represents an average global property, unlike strength which is typically controlled by the locally largest defects in the materials.

6.1. Composites with Random Fiber Orientation. Composites with an in-plane random fiber orientation distribution, which is usually the case for wood fiber composites, can be regarded as a stack of unidirectional plies, where the relative thickness of each ply is determined from the fiber orientation distribution. This is known as a laminate analogy, where classic laminate mechanics can be used to relate the elastic properties of the hypothetical unidirectional ply to those of the composite plate. The laminate analogy is schematically illustrated in Figure 4. It is assumed that the fiber orientation distribution

is symmetric, which is typically the case for wood fiber mats produced with conventional wet-forming techniques [65]. This means that the materials are globally orthotropic, and the global stiffness matrix can be described by five elastic constants, namely the longitudinal and transverse Young's moduli, the major and minor Poisson ratios, and the shear modulus. The components in the global stiffness matrix can be determined from standardized macroscopic testing, and the fiber orientation distribution can be found by image analysis of scanned sections of the fiber mat [66].

Softwood pulp fibers have an aspect ratio of about 100 [67]. From a mechanical point of view, these fibers can be regarded as continuous, that is, of infinite length, since the ineffective lengths close to the fiber ends are relatively small, as can be calculated by shear-lag theories [68, 69]. The stiffness contribution of wood fibers to the unidirectional plies in the laminate analogy can then be described by simple mechanical models, such as the rule of mixtures model for the longitudinal elastic properties, and the Halpin-Tsai model for the transverse and shear elastic properties (e.g., [70]). For the off-axis properties, Hashin's concentric cylinder model is more accurate [71]. The latter model has been used by Neagu et al. [72] to back-calculate the contributing stiffness of wood fibers from the measured stiffness of composites, and thereby

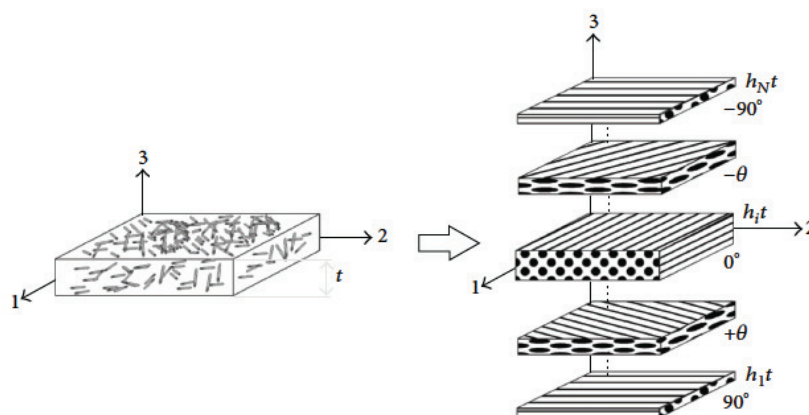

FIGURE 4: Schematic illustration of a laminate analogy for randomly oriented cellulose fiber composites.

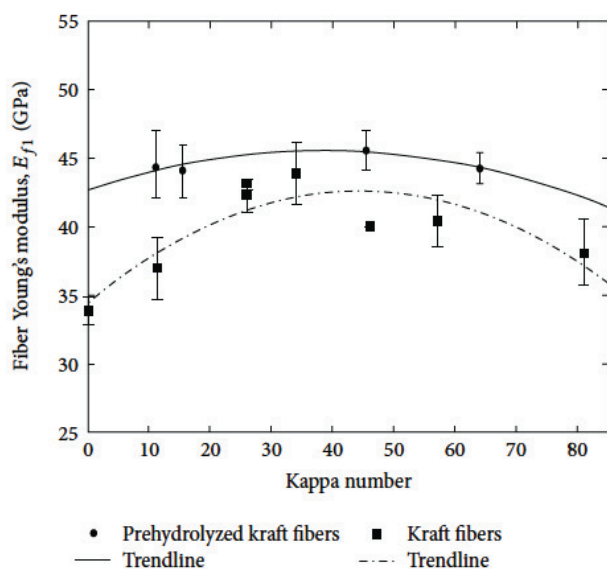

FIGURE 5: The effect of bleaching level, as characterized by the kappa number, on the contributing fiber stiffness in softwood fiber composites. Shown are results from laboratory softwood kraft fibers and prehydrolyzed kraft fibers [72].

ranking different chemical treatments of wood fibers with respect to their reinforcement efficiency in composites. An example is shown in Figure 5, where the effect of bleaching and retained lignin (characterized by the kappa number) on the contributing fiber stiffness is plotted. This serves as an illustration on how the micromechanical approach can be used to find the optimal bleaching level irrespective of the fiber content and fiber orientation in the composites. These last two parameters may be hard to control in a reproducible manner in the manufacturing of composites.

6.2. Composites with Non-Negligible Porosity Content. In cellulose fiber composites, the porosity typically makes a noteworthy contribution to the overall composite volume with porosity contents up to 10% [62]. In contrast, in glass and

carbon fiber composites, considerable knowledge has been accumulated to diminish the porosity contents below 1% [73]. Altogether, porosity can typically not be neglected in cellulose fiber composites, and it should be integrated in the evaluation of composite performance.

Figure 6 shows examples of the three types of porosity that typically can be found in cellulose fiber composites: fiber lumen porosity, interface porosity, and impregnation porosity. In a study by Madsen et al. [62], the porosity content is correlated with the fiber and matrix contents, and a model for the numerical correlation between weight and volume contents of the composite constituents is presented. Input parameters are (i) the density of fibers and matrix, which can be measured by pycnometry and buoyancy methods, (ii) a number of empirical porosity constants, which can be measured from images of composite microstructures, and (iii) the maximum obtainable fiber volume fraction, which can be determined from the compaction behavior of the fiber assembly. The model predicts the volume fractions of fibers, matrix and porosity as a function of the fiber weight fraction. The model applies to composites in general, but it is particular relevant to composites with a relatively high porosity content, which is typically the case for cellulose fiber composites.

Figure 7(a) shows experimental data and model predictions of the volumetric composition of a series of unidirectional flax fiber/thermoplastic matrix composites with variable fiber weight fractions. The volume fractions of fibers and porosity are increased as a function of the fiber weight fraction, until a certain value where after the fiber volume fraction is constant, and the porosity starts to increase more dramatically. The transition fiber weight fraction is determined to be 0.61. Thus, the given composites should be manufactured with a fiber weight fraction of 0.61 to have the best possible combination of high fiber volume fraction, and low porosity, and as will be shown next, this leads to composites with a maximum obtainable tensile stiffness.

The predictions of the volumetric composition in composites can be integrated with micromechanical models. This has been done in the study by Madsen et al. [74] by applying the rule of mixtures model for stiffness of composites. A modified version of the model was used in which the effect

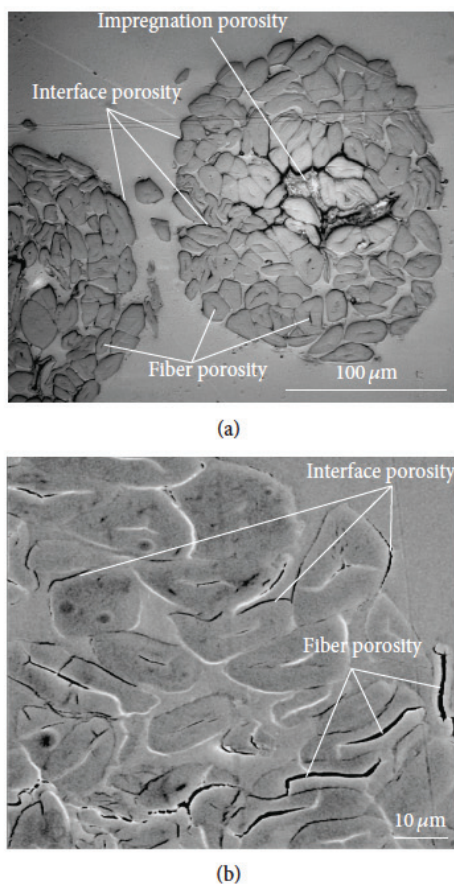

FIGURE 6: Types of porosity in cellulose fiber composites. Shown are cross-sectional images of unidirectional hemp fiber/polyethylene terephthalate composites. The optical microscope image in (a) shows a hemp fiber yarn, and the scanning electron microscope image in (b) shows a close-up of the fibers in the yarn [62].

of porosity giving stress concentrations in the composites was included. Figure 7(b) shows experimental data and model predictions for stiffness of the unidirectional flax fiber/thermoplastic matrix composites. Stiffness is increased monotonically as a function of the fiber weight fraction until a certain value where after it starts to decrease. The transition fiber weight fraction is 0.61 (i.e., the value determined from the modeling of the volumetric composition of the composites), and here the composites show a maximum obtainable stiffness of about 35 GPa. It demonstrates that the models can be used as guidelines for design of composites with a non-negligible porosity content, such as cellulose fiber composites, to have optimal volumetric composition leading to optimal mechanical performance.

7. Moisture Sensitivity of Composites

Compared to composites with conventional fibers, the Achilles' heel of cellulose fiber composites is their propensity to take up moisture, which leads to swelling, dimensional

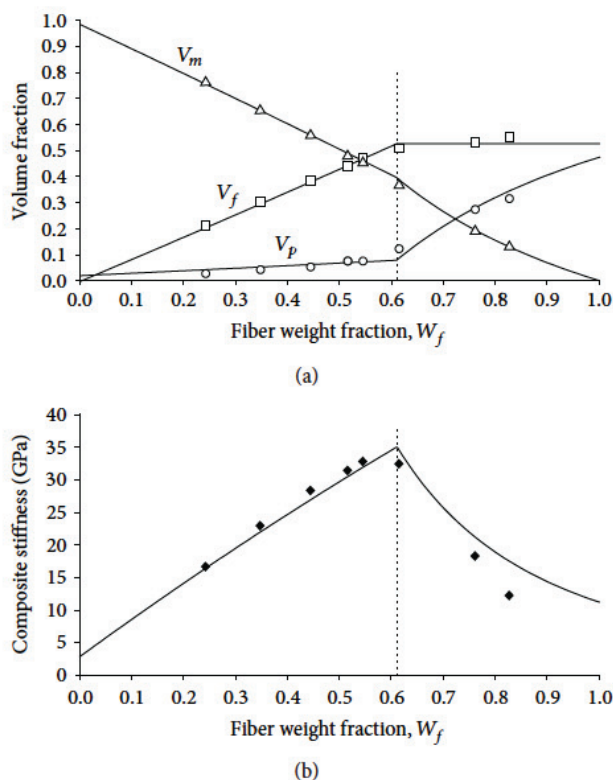

FIGURE 7: Experimental data and model predictions of (a) volumetric composition (V_f , V_m , and V_p) and (b) stiffness as a function of the fiber weight fraction of unidirectional flax fiber/polyethylene terephthalate composites. Vertical dotted lines indicate the transition fiber weight fraction. Data from [75].

instability, and potential degradation of mechanical properties. The hydrophilicity of the fibers is due to the abundance of available hydroxyl groups in hemicellulose, in amorphous cellulose and at the surface of cellulose crystallites. For structural materials, moisture sensitivity is generally considered to be a disadvantage, and should be reduced, if possible. For cellulose fiber composites, this can be done by cross-linking of the cell wall polymers in the fibers [76], use of a stiff and hydrophobic matrix [77], and use of a moisture barrier coating [78].

How the swelling of the fibers affects the dimensional stability of the composites is complicated due to the irregular microstructure of the fiber assembly. One way to isolate the hygroexpansion of the fibers, and to quantify its contribution to the hygroexpansion of the composites, is to use micromechanical models. These are similar to models primarily developed for thermal expansion and residual stresses in ceramic-matrix composites. Thermal expansion and hygroexpansion are governed by the same physical equations, where thermal and hygral strains are governed by temperature and moisture, respectively. The micromechanical models for hygroexpansion of composites include also parameters for the elastic properties of the fiber and matrix constituents. In a study by Neagu et al. [48], curl measurements of strips of wood fiber composites and wood fiber mats were used to determine the

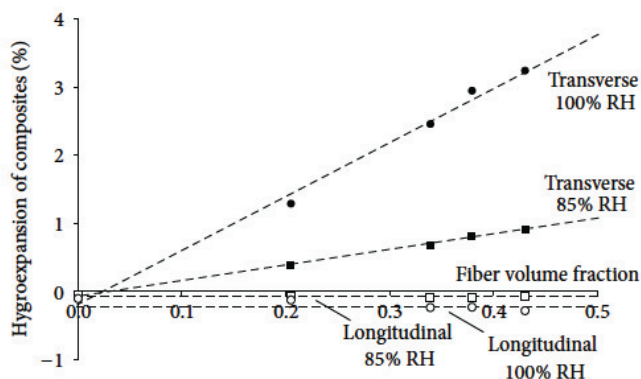

FIGURE 8: Hydroexpansion of unidirectional hemp fiber/polyethylene terephthalate composites as function of the fiber volume fraction. Hydroexpansion was measured in the longitudinal and transverse directions, and at the humidities of 85 and 100% RH, with respect to a reference humidity of 65% RH. Lines are calculated by micromechanical models. Modified from [80].

transverse hydroexpansion coefficient of wood fibers to be approximately 0.10 strain per relative moisture content. This is in accordance with a few scarce data found in the literature on the hydroexpansion properties of cellulose fibers [79].

In a study by Madsen et al. [80] of the hydroexpansion of unidirectional hemp fiber/thermoplastic matrix composites, the dimensional changes were found to be well correlated with the fiber volume fraction. Selected results are shown in Figure 8. By using a reference humidity of 65% RH, the transverse hydroexpansion was found to be 0.9% and 3.3% at humidities of 85 and 100% RH, respectively, for composites with the highest fiber volume fraction of 0.43. The hydroexpansion in the longitudinal direction was found to be low, and slightly negative, which presumably is due to moisture induced relaxation of residual tensile stresses in the matrix. It can be observed in the figure that the experimental data points are well simulated by the micromechanical model lines.

Glass and carbon fibers do not take up any moisture, although glass fibers are sensitive to environmental stress corrosion in the presence of moisture and tensile stress [81]. The moisture sensitivity is larger for wood fibers than for plant fibers, since the former contains a larger relative amount of hemicellulose which is the most hydrophilic polymer in the cell wall.

8. Applications of Composites

In Europe, cellulose fiber composites are mainly used by the automotive industry. The applied fiber preforms are loose fibers used for injection molding techniques, and non-woven mats used for compression molding techniques. Due to the nominal random fiber orientation in these composites, they possess only moderate mechanical properties (see Table 2), but this makes them nevertheless well qualified to be used in non-structural components such as door liners, boot liners, and parcel shelves. The low prices of loose fibers and non-woven mats of cellulose fibers, compared to their synthetic

counterparts, form a strong motivation for the use of these two preforms in the automotive industry. Outside Europe, the use of non-structural components based on cellulose fibers is more widespread, and wood fibers are by far the preferred fiber type. In North America, the main applications are building components, such as deckings, windows profiles and floorings.

Recently, in the context of research and development projects, a number of demonstrators have been made to reveal the good potential of cellulose fiber composites in new kinds of applications (see Figure 9).

- (i) *Sculpture* shown at the Louisiana Museum of Modern Arts, Denmark, special exhibition “Green architecture for the future”, winner of the JEC innovation award 2010, joint venture of 20 companies coordinated by 3XN architects, Denmark.
- (ii) *Wheel rim*, EU 7th Framework Programme project, NATEX (2008–2012).
- (iii) *Chair for children*, developed by the research institute Innventia AB together with pulp industry and architects, exhibited at the Milan furniture fair 2009.
- (iv) *Double-curvature panels* designed by M. Larsen and K.R. Nielsen, exhibited at “Klimaforum09/Ideas at work” in connection with COP15, Copenhagen 2009, and at the JEC exhibition 2010.
- (v) *Small-scale rotor blade* to be used for a wind turbine car, EU 7th Framework Programme project, WOODY (2009–2012).
- (vi) *Exhibition stands* at the Swedish Nautical Historical Museum in Stockholm, Sweden, EU 7th Framework Programme Project, WOODY (2009–2012).

9. Future Perspectives: Nanofiber Composites

In recent years, considerable attention has been directed towards composites made from cellulose nanofibers (e.g., [82]). As already described, the cell wall of wood and plant fibers is structured like composites with cellulose microfibrils embedded in a matrix of hemicellulose and lignin. The cellulose microfibrils are having lateral dimensions in the 10–100 nm range and axial dimensions in the micrometer range, and they are therefore suitable as reinforcement in nanofiber composites. The idea is to achieve considerable improvements in engineering properties with the addition of nanofibers, beyond those obtained with fibers in the micrometer range. This can be attributed to the high specific surface area of the nanoscale fibers, which will affect the properties of the surrounding matrix. The success of nanofiber composites is particularly obvious if only a minute addition of fibers is considered, and the dispersion of nanofibers is preserved.

Carbon nanotube composites have shown great promise for a relatively long time, but have yet to deliver in large volume applications [83]. A difference between cellulose nanofibers and carbon nanotubes is the ability of the cellulose nanofibers to bond to each other, by hydrogen bonding, whereas the carbon nanotube surface is chemically inert.



FIGURE 9: Examples of new applications of cellulose fiber composites: (top, left) sculpture, (top, right) wheel rim, (middle, left) chair for children, (middle, right) double-curvature panels, (bottom, left) small-scale rotor blade, and (bottom, right) exhibition stand. See text for more details.

The cellulose nanofibers can form a very strong network, and furthermore bond well to polymer matrix materials with polar groups. This leads however also to processing difficulties, since the cellulose nanofibers tend to aggregate and take a long time to dry after wet processing. Processability and performance are thus complementary and mutually opposing behaviors. The functional hydroxyl groups of the fibers can be modified to improve dispersion and processability, although this is typically accompanied with increased costs. The main challenges for cellulose nanofiber composites are probably to learn how to manufacture bulk composite components with retained nanofiber slenderness and dispersion. The raw materials are the cellulose fibers themselves, from wood pulp or plant fibers, making the raw materials costs negligible compared with manufacturing costs.

10. Overall Comparison between Fibers

As shown in the sections above, wood and plant fibers are similar in some respects and differ in others. Thus,

depending on the intended application, one particular fiber type is more suitable than the other. In the following, an overall comparison is given to highlight some advantages of wood versus plant fibers, and vice versa. Similarly, cellulose fibers are compared to their synthetic counterparts, glass and carbon fibers.

Advantages of wood fibers, as compared with plant fibers, are as follows.

- (i) Low cost, readily available from pulp mills.
- (ii) Relatively short fibers mean better processability.
- (iii) Mature infrastructure available in pulp and paper mills to produce large quantities at low cost.
- (iv) Preforms can be made using paper-making technologies.
- (v) Rather uniform batches of pulp qualities can be achieved.
- (vi) Does not compete with cultivation of food crops.

Advantages of plant fibers, as compared with wood fibers, are as follows.

- (i) High productivity and yield.
- (ii) High cellulose content, high degree of cellulose crystallinity, low microfibril angle, small lumen mean excellent mechanical properties of fibers.
- (iii) Relatively long fibers means possibility to control fiber orientation and lay-up.
- (iv) Textile technologies can be used to produce yarns, woven fabrics and non-crimp fabrics.

Despite the differences, wood and plant fibers have more in common than in what differ them from one another. Some advantages of cellulose fibers as compared with glass and carbon fibers can be mentioned.

- (i) Renewable.
- (ii) Biodegradable.
- (iii) Light, that is, the composites have good specific properties which are important in automotives and packaging.
- (iv) Low cost raw materials.

The main disadvantages of cellulose fibers as compared with glass and carbon fibers are as follows.

- (i) Moderate mechanical properties.
- (ii) Sensitivity to moisture, leading to dimensional instability, and potential degradation of mechanical properties.
- (iii) Not fully developed composite manufacturing techniques.

The above lists are by no means comprehensive, but only serve to show some of the traits of wood and plant fibers in an applied composite context. In the further development of cellulose fiber composites, both advantages and disadvantages play an important role. The specific advantages guide which application areas that are relevant. For instance, the combination of low cost, renewability and biodegradability make cellulose fiber composites suitable materials for packaging applications. The disadvantages limit their applications. Research on how to alleviate these shortcomings can expand the proliferation of cellulose fibers as an eco-friendly alternative to synthetic fibers. If cellulose fibers can be processed to retain better their innate high stiffness and strength, and they can be modified to become less hydrophilic they are also potential reinforcement fibers in advanced structural outdoor applications, for example, in rotor blades for wind turbines and in load-carrying components in transport applications.

References

- [1] A. K. Mohanty, M. Misra, and L. T. Drzal, *Natural Fibers, Biopolymers, and Biocomposites*, CPR Press, Boca Raton, Fla, USA, 2005.
- [2] K. L. Pickering, *Properties and Performance of Natural-Fibre Composites*, Woodhead Publishing Limited, Cambridge, UK, 2008.
- [3] J. Müssig, *Industrial Applications of Natural Fibres—Structure, Properties and Technical Applications*, John Wiley & Sons, Chichester, UK, 2010.
- [4] CELC European Scientific Committee, “Flax and hemp fibres: a natural solution for the composite industry,” in *European Hemp and Flax Confederation*, F. Reux and I. Verpoest, Eds., JEC Composites Group, Paris, France, 2012.
- [5] C. Hill and M. Hughes, “Natural fibre reinforced composites opportunities and challenges,” *Journal of Biobased Materials and Bioenergy*, vol. 4, no. 2, pp. 148–158, 2010.
- [6] E. Zini and M. Scandola, “Green composites: an overview,” *Polymer Composites*, vol. 32, pp. 1905–1915, 2011.
- [7] O. Faruk, A. K. Bledzki, H. Fink, and M. Sain, “Biocomposites reinforced with natural fibers: 2000–2010,” *Progress in Polymer Science*, vol. 37, pp. 1552–1596, 2012.
- [8] A. Shahzad, “Hemp fiber and its composites—a review,” *Journal of Composite Materials*, vol. 46, pp. 973–986, 2012.
- [9] J. F. Siau, *Wood: Influence of Moisture on Physical Properties*, Department of Wood Science and Forest Products, Virginia Polytechnic Institute and State University, Burruss Hall, Va, USA, 1995.
- [10] D. R. Perry, *Identification of Textile Materials*, The Textile Institute, Manchester, UK, 7th edition, 1985.
- [11] H. Lilholt and J. M. Lawther, “Natural organic fibers,” in *Comprehensive Composite Materials*, A. Kelly and C. Zweben, Eds., vol. 1, chapter 10, pp. 303–325, Elsevier Science, 2000.
- [12] S. E. Anagnost, R. E. Mark, and R. B. Hanna, “Variation of microfibril angle within individual tracheids,” *Wood and Fiber Science*, vol. 34, no. 2, pp. 337–349, 2002.
- [13] J. Gassan, A. Chate, and A. K. Bledzki, “Calculation of elastic properties of natural fibers,” *Journal of Materials Science*, vol. 36, no. 15, pp. 3715–3720, 2001.
- [14] B. Madsen, P. Hoffmeyer, A. B. Thomsen, and H. Lilholt, “Hemp yarn reinforced composites—I. Yarn characteristics,” *Composites Part A*, vol. 38, no. 10, pp. 2194–2203, 2007.
- [15] J. Lindhagen and L. Berglund, “Microscopical damage mechanisms in glass fiber reinforced polypropylene,” *Journal of Applied Polymer Science*, vol. 69, no. 7, pp. 1319–1327, 1998.
- [16] A. Ridruejo, C. Gonzalez, and J. LLorca, “Damage micromechanisms and notch sensitivity of glass-fiber non-woven felts: An Experimental and Numerical Study,” *Journal of the Mechanics and Physics of Solids*, vol. 58, pp. 1628–1645, 2010.
- [17] R. C. Neagu, E. K. Gamstedt, S. L. Bardage, and M. Lindström, “Ultrastructural features affecting mechanical properties of wood fibers,” *Wood Materials Science & Engineering*, vol. 1, pp. 146–170, 2006.
- [18] L. Salmén and I. Burgert, “Cell wall features with regard to mechanical performance. A review. COST Action E35 2004–2008: wood machining—Micromechanics and fracture,” *Holz-forschung*, vol. 63, no. 2, pp. 121–129, 2009.
- [19] L. Salmén, “Micromechanical understanding of the cell-wall structure,” *Comptes Rendus—Biologies*, vol. 327, no. 9–10, pp. 873–880, 2004.
- [20] A. Thygesen, A. B. Thomsen, G. Daniel, and H. Lilholt, “Comparison of composites made from fungal defibrated hemp with composites of traditional hemp yarn,” *Industrial Crops and Products*, vol. 25, no. 2, pp. 147–159, 2007.

- [21] K. Hofstetter, C. Hellmich, and J. Eberhardsteiner, "Development and experimental validation of a continuum micromechanics model for the elasticity of wood," *European Journal of Mechanics A*, vol. 24, no. 6, pp. 1030–1053, 2005.
- [22] K. Hofstetter, C. Hellmich, and J. Eberhardsteiner, "The influence of the microfibril angle on wood stiffness: a continuum micromechanics approach," *Computer Assisted Mechanics and Engineering Sciences*, vol. 13, no. 4, pp. 523–536, 2006.
- [23] D. H. Page, F. El-Hosseiny, and K. Winkler, "Behaviour of single wood fibres under axial tensile strain," *Nature*, vol. 229, no. 5282, pp. 252–253, 1971.
- [24] L. Salmén and A. de Ruvo, "A model for the prediction of fiber elasticity," *Wood Fiber Science*, vol. 17, pp. 336–350, 1985.
- [25] A. Thygesen, J. Oddershede, H. Lilholt, A. B. Thomsen, and K. Ståhl, "On the determination of crystallinity and cellulose content in plant fibres," *Cellulose*, vol. 12, no. 6, pp. 563–576, 2005.
- [26] E. Sjöström, *Wood Chemistry, Fundamentals and Applications*, Academic Press, San Diego, Calif, USA, 2nd edition, 1993.
- [27] T. Liittä, S. L. Maunu, B. Hortling, T. Tamminen, O. Pekkala, and A. Varhimo, "Cellulose crystallinity and ordering of hemicelluloses in pine and birch pulps as revealed by solid-state NMR spectroscopic methods," *Cellulose*, vol. 10, no. 4, pp. 307–316, 2003.
- [28] R. Rowell, *The Chemistry of Solid Wood*, American Chemical Society, Washington, DC, USA, 1984.
- [29] A. Thygesen, B. Madsen, A. B. Bjerre, and H. Lilholt, "Cellulosic fibers: effect of processing on fiber bundle strength," *Journal of Natural Fibers*, vol. 8, pp. 161–175, 2011.
- [30] C. M. Clemons, "Woodfiber-plastic composites in the United States—history and current and future markets," in *Proceedings of the 3rd International Wood and Natural Fiber Composites Symposium*, pp. 1–7, Kassel, Germany, September 2000.
- [31] N. E. Marcovich, M. M. Reboledo, and M. I. Aranguren, "Composites from sawdust and unsaturated polyester," *Journal of Applied Polymer Science*, vol. 61, no. 1, pp. 119–124, 1996.
- [32] R. T. Woodhams, G. Thomas, and D. K. Rodgers, "Wood fibers as reinforcing fillers for polyolefins," *Polymer Engineering and Science*, vol. 24, no. 15, pp. 1166–1171, 1984.
- [33] M. Bengtsson, M. L. Baillif, and K. Oksman, "Extrusion and mechanical properties of highly filled cellulose fibre-polypropylene composites," *Composites Part A*, vol. 38, no. 8, pp. 1922–1931, 2007.
- [34] H. L. Cox and K. W. Pepper, "Paper-base plastics—part I: the preparation of phenolic laminated boards," *Journal of the Society of Chemical Industry*, vol. 63, pp. 150–154, 1944.
- [35] K. Näntinen, S. Hyvärinen, R. Joffe, L. Wallström, and B. Madsen, "Naturally compatible: starch acetate/cellulosic fiber composites. I. processing and properties," *Polymer Composites*, vol. 31, no. 3, pp. 524–535, 2010.
- [36] H. Toftegaard, "Tensile testing of jute/PP laminates," Risø Report Risø-I-1824(EN), Risø National Laboratory, Materials Research Department, Roskilde, Denmark, 2002.
- [37] T. L. Andersen and D. Plackett, *Polymer Composite Product, A Process for the Manufacture Thereof and Use of the Product*, International Application Number: PCT/DK02/00085. International Publication Number: WO 02/064670 A1, August 2002.
- [38] B. Madsen, H. Lilholt, A. Thygesen, E. Arnold, B. Weager, and R. Joffe, "Aligned flax fibre/poly lactate composites—a materials model system to show the potential of biocomposites in engineering applications," *Journal of Nanostructured Polymers and Nanocomposites*, vol. 4, no. 4, pp. 139–145, 2009.
- [39] F. Bottoli and L. Pignatti, *Design and processing of structural components in biocomposite materials—Case study: rotor blade for wind turbine cars [M.S. thesis]*, Materials Research Division, Risø National Laboratory for Sustainable Energy, Technical University of Denmark, 2011.
- [40] I. Van de Weyenberg, J. Ivens, A. De Coster, B. Kino, E. Baetens, and I. Verpoest, "Influence of processing and chemical treatment of flax fibres on their composites," *Composites Science and Technology*, vol. 63, no. 9, pp. 1241–1246, 2003.
- [41] S. Mehmood and B. Madsen, "Properties and performance of flax yarn/thermoplastic polyester composites," *Journal of Reinforced Plastics and Composites*, vol. 31, pp. 62–73, 2012.
- [42] J. L. Thomason, "The influence of fibre length and concentration on the properties of glass fibre reinforced polypropylene. 6. the properties of injection moulded long fibre PP at high fibre content," *Composites Part A*, vol. 36, no. 7, pp. 995–1003, 2005.
- [43] E. K. Gamstedt, L. A. Berglund, and T. Peijs, "Fatigue mechanisms in unidirectional glass-fibre-reinforced polypropylene," *Composites Science and Technology*, vol. 59, no. 5, pp. 759–768, 1999.
- [44] K. Oksman, "Mechanical properties of natural fibre mat reinforced thermoplastic," *Applied Composite Materials*, vol. 7, no. 5–6, pp. 403–414, 2000.
- [45] A. R. Bunsell and J. Renard, *Fundamentals of Fibre Reinforced Composite Materials*, Institute of Physics, London, UK, 2005.
- [46] K. M. Almgren, E. K. Gamstedt, P. Nygård, F. Malmberg, J. Lindblad, and M. Lindström, "Role of fibre-fibre and fibre-matrix adhesion in stress transfer in composites made from resin-impregnated paper sheets," *International Journal of Adhesion and Adhesives*, vol. 29, no. 5, pp. 551–557, 2009.
- [47] M. Lindström, F. Berthold, K. Gamstedt, J. Varna, and K. Wickholm, "Hierarchical design as a tool in materials development," in *Proceedings of the 10th International Conference on Progress in Biofiber Plastic Composites*, pp. 1–7, Toronto, Canada, 2008.
- [48] R. C. Neagu, E. K. Gamstedt, and M. Lindström, "Influence of wood-fibre hygroexpansion on the dimensional instability of fibre mats and composites," *Composites Part A*, vol. 36, no. 6, pp. 772–788, 2005.
- [49] M. Eriksen and B. E. Pallesen, *New Generation Airforming for Flax and Hemp*, Nonwovens World, 2002.
- [50] H. S. Kim, B. Pourdeyhimi, A. Abhiraman, and P. Desai, "Characterization of structural changes in nonwoven fabrics during load-deformation experiments," *Journal of Textile and Apparel, Technology and Management*, vol. 1, no. 1, pp. 1–6, 2000.
- [51] P. Grosberg and C. Iype, *Yarn Production—Theoretical Aspects*, The Textile Institute, Manchester, UK, 1999.
- [52] S. Goutianos, T. Peijs, B. Nystrom, and M. Skrifvars, "Development of flax fibre based textile reinforcements for composite applications," *Applied Composite Materials*, vol. 13, no. 4, pp. 199–215, 2006.
- [53] M. Rask, *Microstructure and mechanical properties of aligned natural fibre composites [Ph.D. thesis]*, Department of Wind Energy, Technical University of Denmark. DTU Wind Energy E, 2012.
- [54] D. U. Shah, P. J. Schubel, P. Licence, and M. J. Clifford, "Determining the minimum, critical and maximum fibre content for twisted yarn reinforced plant fibre composites," *Composites Science and Technology*, vol. 72, pp. 1909–1917, 2012.
- [55] J. Gassan and A. K. Bledzki, "Effect of cyclic moisture absorption desorption on the mechanical properties of silanized jute-epoxy composites," *Polymer Composites*, vol. 20, no. 4, pp. 604–611, 1999.

- [56] A. N. Towo and M. P. Ansell, "Fatigue evaluation and dynamic mechanical thermal analysis of sisal fibre-thermosetting resin composites," *Composites Science and Technology*, vol. 68, no. 3-4, pp. 925-932, 2008.
- [57] S. Liang, P. B. Gning, and L. Guillaumat, "A comparative study of fatigue behaviour of flax/epoxy and glass/epoxy composites," *Composites Science and Technology*, vol. 72, pp. 535-543, 2012.
- [58] D. U. Shah, P. J. Schubel, M. J. Clifford, and P. Licence, "Fatigue life evaluation of aligned plant fibre composites through S-N curves and constant-life diagrams," *Composites Science and Technology*, vol. 74, pp. 139-149, 2013.
- [59] J. Gassan and A. K. Bledzki, "Influence of fiber surface treatment on the creep behavior of jute fiber-reinforced polypropylene," *Journal of Thermoplastic Composite Materials*, vol. 12, no. 5, pp. 388-398, 1999.
- [60] H. P. S. A. Khalil, H. Ismail, H. D. Rozman, and M. N. Ahmad, "Effect of acetylation on interfacial shear strength between plant fibres and various matrices," *European Polymer Journal*, vol. 37, no. 5, pp. 1037-1045, 2001.
- [61] G. E. Myers, I. S. Chahyadi, C. A. Coberly, and D. S. Ermer, "Wood flour/polypropylene composites: influence of maleated polypropylene and process and composition variables on mechanical properties," *International Journal of Polymeric Materials*, vol. 15, pp. 21-44, 1991.
- [62] B. Madsen, A. Thygesen, and H. Lillholt, "Plant fibre composites—porosity and volumetric interaction," *Composites Science and Technology*, vol. 67, no. 7-8, pp. 1584-1600, 2007.
- [63] B. Madsen and H. Lillholt, "Compaction of plant fiber assemblies in relation to composite fabrication," in *Proceedings of the 23rd Risø International Symposium on Materials Science. Sustainable Natural and Polymeric Composites—Science and Technology*, pp. 239-250, Risø National Laboratory, 2002.
- [64] M. Hughes, "Defects in natural fibres: their origin, characteristics and implications for natural fibre-reinforced composites," *Journal of Materials Science*, vol. 47, pp. 599-609, 2012.
- [65] A. L. Erikilä, P. Pakarinen, and M. Odell, "Sheet forming studies using layered orientation analysis: can lead to a better understanding of the drainage process," *Pulp and Paper Canada*, vol. 99, no. 1, pp. 81-85, 1998.
- [66] F. Gadala-Maria and F. Parsi, "Measurement of fiber orientation in short-fiber composites using digital image processing," *Polymer Composites*, vol. 14, no. 2, pp. 126-131, 1993.
- [67] J. Duanmu, E. K. Gamsted, and A. Rosling, "Synthesis and preparation of crosslinked allylglycidyl ether-modified starch-wood fibre composites," *Starch*, vol. 59, no. 11, pp. 523-532, 2007.
- [68] H. L. Cox, "The elasticity and strength of paper and other fibrous materials," *British Journal of Applied Physics*, vol. 3, no. 3, article 302, pp. 72-79, 1952.
- [69] J. A. Nairn, "On the use of shear-lag methods for analysis of stress transfer in unidirectional composites," *Mechanics of Materials*, vol. 26, no. 2, pp. 63-80, 1997.
- [70] E. K. Gamstedt, E. Sjöholm, C. Neagu, F. Berthold, and M. Lindström, "Effects of fiber bleaching and earlywood-latewood fraction on tensile properties of wood-fiber reinforced vinyl ester," in *Proceedings of the 23rd Risø International Symposium on Materials Science: Sustainable Natural and Polymeric Composites—Science and Technology*, H. Lillholt, Ed., pp. 185-196, Risø National Laboratory, 2002.
- [71] Z. Hashin, "Stiffness contribution of various wood fibers to composite materials," *Journal of Applied Mechanics*, vol. 46, no. 3, pp. 543-550, 1979.
- [72] R. C. Neagu, E. K. Gamstedt, and F. Berthold, "Stiffness contribution of various wood fibers to composite materials," *Journal of Composite Materials*, vol. 40, no. 8, pp. 663-699, 2006.
- [73] J. A. E. Månson, M. D. Wakeman, and N. Bernet, "Composite processing and manufacturing—an overview," in *Comprehensive Composite Materials*, A. Kelly and C. Zweben, Eds., vol. 2, chapter 2, pp. 577-607, Elsevier Science, 2000.
- [74] B. Madsen, A. Thygesen, and H. Lillholt, "Plant fibre composites—porosity and stiffness," *Composites Science and Technology*, vol. 69, no. 7-8, pp. 1057-1069, 2009.
- [75] M. Aslan, S. Mehmood, and B. Madsen, "Effect of consolidation pressure on volumetric composition and stiffness of unidirectional flax fibre composites," *Journal of Materials Science*, vol. 48, no. 10, pp. 3812-3824, 2013.
- [76] C. A. S. Hill, H. P. S. A. Khalil, and M. D. Hale, "A study of the potential of acetylation to improve the properties of plant fibres," *Industrial Crops and Products*, vol. 8, no. 1, pp. 53-63, 1998.
- [77] K. M. Almgren, E. K. Gamstedt, F. Berthold, and M. Lindström, "Moisture uptake and hygroexpansion of wood fiber composite materials with polylactide and polypropylene matrix materials," *Polymer Composites*, vol. 30, no. 12, pp. 1809-1816, 2009.
- [78] C. Esnaashari, S. N. Khorasani, M. Entezam, and S. Khalili, "Mechanical and water absorption properties of sawdust-low density polyethylene nanocomposite," *Journal of Applied Polymer Science*, vol. 127, pp. 1295-1300, 2013.
- [79] K. M. Almgren, E. K. Gamstedt, and J. Varna, "Contribution of wood fiber hygroexpansion to moisture induced thickness swelling of composite plates," *Polymer Composites*, vol. 31, no. 5, pp. 762-771, 2010.
- [80] B. Madsen, P. Hoffmeyer, and H. Lillholt, "Hemp yarn reinforced composites—III Moisture content and dimensional changes," *Composites Part A*, vol. 43, pp. 2151-2160, 2012.
- [81] E. L. Rodriguez, "Corrosion of glass fibres," *Journal of Materials Science Letters*, vol. 6, no. 6, pp. 718-720, 1987.
- [82] S. J. Eichhorn, A. Dufresne, M. Aranguren et al., "Review: current international research into cellulose nanofibres and nanocomposites," *Journal of Materials Science*, vol. 45, no. 1, pp. 1-33, 2010.
- [83] Y. Dzenis, "Spinning continuous fibers for nanotechnology," *Science*, vol. 304, no. 5679, pp. 1917-1919, 2004.